

1

2

3

4

5

COMPONENT SPECIFICATION

USE OR REPRODUCTION OF THIS DRAWING FOR THE PURPOSE OF MANUFACTURING THIS ARTICLE OR ANY ARTICLES SHOWN FOR ANY PURPOSE IS STRICTLY PROHIBITED WITHOUT WRITTEN PERMISSION FROM SENIOR INDUSTRIES, INC.

SPECIFICATIONS:

MECHANICAL:

RANGE: #14-#10 COPPER GROUND WIRE.
INSTALLATION TORQUE: APPROX. 11 IN-LBS MIN.
AGENCY APPROVALS: UL/CUL FILE NO. E137532

MATERIAL:

BRACKET - .048" THICK STEEL, ZINC DICHROMATE FINISH.
NUT - BRASS, NICKEL PLATED.
SCREW - 300 SERIES STAINLESS STEEL.
CLAMPING WASHER - BRASS, NICKEL PLATED

A

B

C

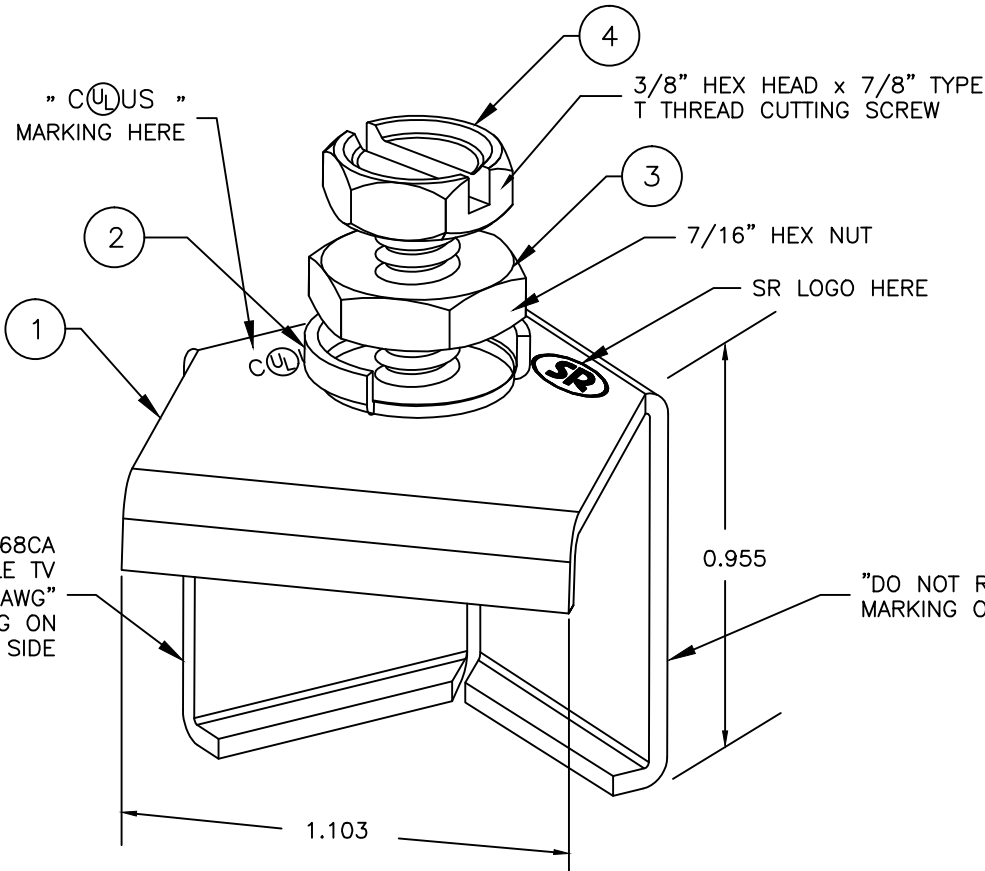

4	10-24 SCREW
3	10-24 NUT
2	CLAMPING WASHER
1	BRACKET
ITEM	DESCRIPTION



DESIGNED:			SYM.	DATE:	DESCRIPTION OF REVISIONS:	DRAWN:	APPD:	TOLERANCE:	PART NO:	SI-2168CA
DRAWN:	HV	04/03/00	▲	12.08.08	NEW	GAT	JF		TO 2 DECIMAL PLACE: ±	TITLE:
CHECKED:	GAT	12/08/08	▲	03.17.14	Revised product markings	MAW	JF	TO 3 DECIMAL PLACES: ±		SHEET:
APPROVED:	JF	12/08/08	▲						AS ANGLES: ±	
3RD ANGLE		UNIT:	inches	SCALE:		REV.	B			